

TIPPER TARPSTM LOAD COVER SYSTEMS

For all types of ground operated load cover systems for:

- End Tippers • Side Tippers
- Walking Floors • Curtainsiders
- Railway Wagons • Loading Bays • Etc



Roll over Side to Side tarps



Wind out Front to Back Tarps

Features-

- 100% Water proof for Grain and Fertilizer
- Extruded Aluminium roll pipe
- Quick release universal joint
- Stainless Steel hardware
- Telescopic crank handle
- 900 GSM fully welded PVC Tarp

Features

- Heavy duty mesh for quarry work, sand, gravel etc
- Stainless steel front shaft
- Zinc plated components
- Low profile cables sit lower than Top Rail to minimise Loader hook up

Options

- Chain drive • Asphalt material
- 80% water resistant system for EPA work
- 100% Water resistant system for grain and fertilizer



Pull Out Tarps



Side Curtains



Tower Tarps



Electric and hydraulic kits for Roll Over tarps



Electric Systems

The Ultimate in Safety and Productivity

Heavy Duty DC motor and worm drive gearbox.

Controlled with cab mounted switches.

Options:

- Remote control
- Auxillary battery

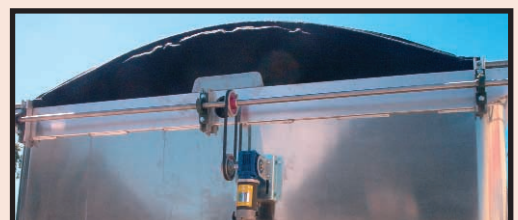

Electric kits for Wind Out tarps

Quality Components



Fit a Tipper Tarp and "DON'T BLOW YOUR LOAD ON THE ROAD"

QUOTATION FORM/MEASURING FORM

Date: _____
 Customer: _____
 Contact: _____
 Address: _____
 State: _____ Postcode: _____

Mobile: _____
 Phone: _____
 Fax: _____
 Email: _____

Order number: _____

Delivery instructions: _____

Specifications

(Please tick)

Type of tarp system

- Wind Out - mesh
- Wind Out - 80% water resistant
- Wind Out - 100% water resistant
- Pull Out System
- Pivoting Arm System
- Roll Over - Headboard style
- Roll Over - Queensland Style
- Other _____

Material

- Quarry Mesh
- Asphalt
- 900 GSM P.V.C
- 650 GSM P.V.C
- Other _____

Body Type

- Rigid Truck
- Dog Trailer
- Semi

Tailgate

- Side swing
- Forward hinged
- Rear top hinged

Construction

- Aluminium
- Steel
- Bisalloy

Make of Body _____

Tarp Colour _____

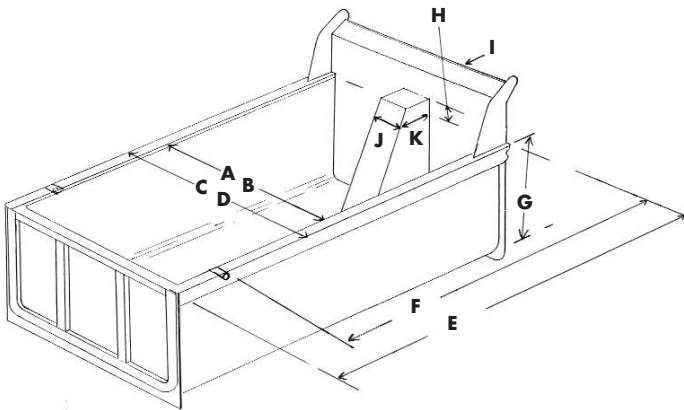

- A: Inside width Front _____
- B: Inside width Rear _____
- C: Outside width Front _____
- D: Outside width Rear _____
- E: Overall length _____
- F: Front of Body to front of hinge _____
- G: Side Height _____
- H: Height of hoist box above sides _____
- I: Distance between Cab & Body _____
- J: Hoist box width at bow height _____
- K: Hoist box depth at bow height _____

Options (Please circle) • Electric 12 volt • Electric 24 volt • Fold up rear flap • Chain drive • Other _____

Payment

- Cash
- Cheque
- Credit Card

Terms

- Up front
- C.O.D
- 30 Days

Price Supply _____ Fit _____ GST _____ **Total \$** _____

Quote valid for 30 days

Notes:

Note: The fitting of some tarp systems may cause the vehicle to exceed the the 2.5m legal width. The decision to fit such a tarp lies entirely with the customer and Tipper Tarps accepts no responsibility for any loss or damages caused by overwidth tarps.